



22-24 SEPTEMBER 2021

BOOKING FORM

(for the booking please print only page 1 and 2)

manufacturer distributor importer service provider Value Added Reseller others

company

street

postal code

town

country

email

website

contact person

salutation

email

phone

mobile

VAT-ID no. (EU states only)

Attention companies based outside the EU: The VAT will not be charged, if the company provides a certificate issued by their domestic tax authority confirming that the exhibitor is a real existing company or an excerpt of the commercial register proving without any doubt that the company does really exist. If no certificate or register excerpt is submitted, we will be obliged to charge VAT.

Invoicing address (if different)

street

postal code

town

country

Stand construction

We only build **sustainable + climate neutral!**

according to service catalogue and description of services

full fair construction incl. full-service package 785 €/m² x _____ m² = _____ €

Obligatory extra costs

Service fee **580 €** WiFi internet connection **270 €**

Leipziger Messe *according to the description of services (Deposits in transit)*

Media fee **184.90 €**

Bannering/wall graphics *according to the floor plan*

1x on top logo panel wooden decoration* (horizontal, 0,5 m high x running front meter) 75,00 €/m x _____ m = _____ €

1x wall graphic*²/ wooden decoration* (2,5 m x running side + back wall meters) 145,00 €/m x _____ m = _____ €

The wall graphics or alternatively walls in a partial wood-decor are a mandatory part of the registration. The entire pavilion is to be presented to the public as a climate-neutral sustainability park, also to avoid the risk of a "green washing" image. Each co-exhibitor can decide, in consultation with the stand builder, how much wall space (in meters) is to be designed as an environmentally-friendly wall graphic or in wood décor finish (the price per m² is identical). Wall graphics data must be transmitted electronically to the stand builder at least 1-2 months prior to the start of the trade fair.

* certified material made of wood from sustainable forest management/** high quality textile wall profile to take home and reuse

media partners



DEALERS ONLY



p. 1 of 7



HALL 5



a project of



GLOBAL FAIRS
TT-MESSE.DE

supported by



22–24 SEPTEMBER 2021

BOOKING FORM

Qualified fair hostesses/hosts

For your trade fair presentation you have the possibility to book professional and multilingual fair hostesses/hosts - 200 €/person/8 hrs. day

Yes, we need 1 or more fair hostesses/hosts

number of Hostesses/Hosts: _____

number of trade fair days: _____

Advert in the SuperReseller

Channel campaign, circulation: approx. 300.000 in print & online

<input type="checkbox"/> 1/1 (front cover)	200 x 150	3.875,00 €
<input type="checkbox"/> 1/1 (back cover)	180 x 260	3.750,00 €
<input type="checkbox"/> 1/2 horizontal o. vertical	180 x 128 bzw. 88 x 260	1.875,00 €
<input type="checkbox"/> 1/3 horizontal o. vertical	180 x 84 bzw. 58 x 260	1.250,00 €
<input type="checkbox"/> ad product	88 x 50	350,00 €

Note:

This offer is only valid for co-exhibitors and already includes 25% discount off the regular price.

A presentation of the company logo is mandatory and included free of charge in the package.

Comments:

Terms of payment:

Immediate payment net cash. The booking is binding when the total amount has been paid to our account by the due date. We reserve the right to let the area to others in case of late payment. Any change to the configuration of the co-exhibitors does not constitute a reason for cancellation. All prices plus VAT, payable immediately net cash. Possible transfer costs are to be paid by the exhibitor himself.

The description of services and general terms and conditions of Global Fairs and the general terms of Leipziger Messe have been noted and are hereby accepted as legally binding. All applicants acting on behalf of another person guarantee to pay all outstanding amounts to the organizer of the trade fair mentioned above.

The area indicated may show tolerance variation of up to 10 % due to the technical situation at the site (m² given = gross size). This fact does not justify a deduction, compensation or cancellation. The organiser reserves the right to change the stand construction during the planning process. Changes in the composition of co-exhibitors or the relocation of the pavillion within the hall or to another adequate hall by the exhibition company are no reason for cancellation or claim for compensation.

In case of any general queries please feel free to contact the Global Fairs team, for queries regarding the booth construction please contact the fair constructor directly. Please go to our website www.global-fairs.de and service catalogue for further information and contact details.

- Hereby I declare that I will commit myself to a climate-friendly and environmentally friendly project handling of my entire exhibition appearance
- In order to achieve a climate-neutral trade fair organization we, Global Fairs TT-Messe commit ourselves to donate a necessary amount calculated according to the FAMAB Foundation's CO2 calculator for the reforestation of forests

X

X

Place/Date

Name in capital letters

Signature/Stamp

media partners



DEALERS ONLY



EXAMPLE CALCULATION FOR WALL GRAPHIC/WOOD DECOR & ON TOP LOGO PANEL

The stand sizes shown are only sample sizes – please look individually at the stand plan for your stand size.

1 CORNER BOOTH – 2 sides open (here: 12 m²):

(booth outside the main area on the hall wall)

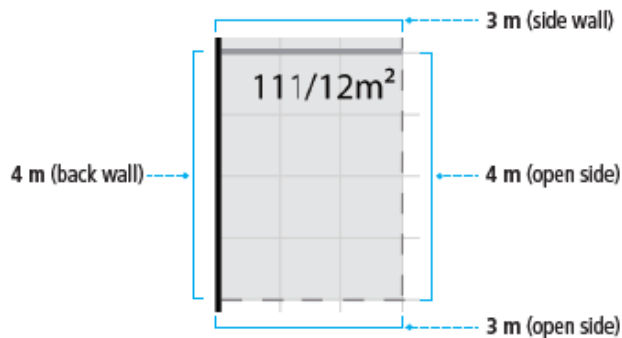

Running front meter: 4 m + 3 m = 7 m
Running wall meter: 4 m + 3 m = 7 m

2 1 OPEN SIDE BOOTH (here: 9 m²):

(booth outside the main area on the hall wall)

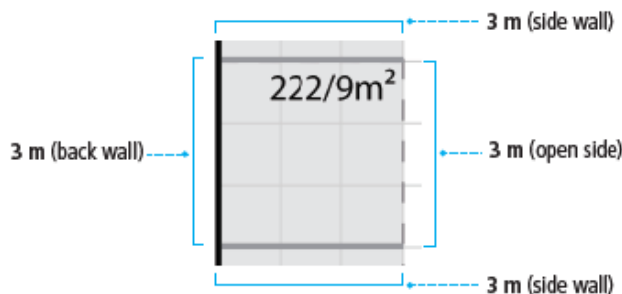

Running front meter: 3 m
Running wall meter: 3 m + 3 m + 3 m = 9 m

3 1 OPEN SIDE BOOTH (here: 15 m²) WITH PASSAGE to the lounge (1m)

(booth in the main area with 1m entrance to the lounge)

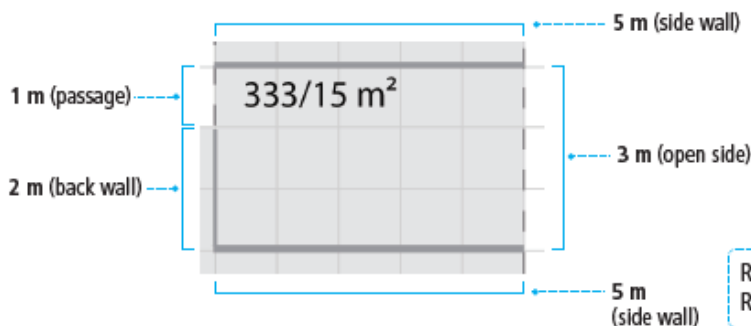

Running front meter: 3 m
Running wall meter: 5 m + 2 m + 5 m = 12 m



LEIPZIGER
MESSE



HALL 5

SUSTAINABLE
FAIR CONSTRUCTION & CATERING



a project of



GLOBAL FAIRS
TT-MESSE.DE

supported by



22–24 SEPTEMBER 2021

DESCRIPTION OF SERVICES

Booth construction version

Full fair construction according to exhibitor service catalogue incl. full service package as per this description of services

785 €/m²

The area indicated may show tolerance variation of up to 10 % due to the technical situation at the site (m² given = gross size). The organizer reserves the right to change the stand construction during the planning process.

Wall graphics and on top logo panels are obligatory for all exhibitors to give a unitary and distinctive image to the pavillion.

The m² price includes:

- ✓ Rented surface area and complete booth construction as per individual layout
- ✓ Mandatory EFA Accessory charges of Leipziger Messe: innovation flat-rate 2.50 €/m², AUMA fee 0.60 €/m²
- ✓ Stand furniture (as per furniture list in the exhibitor service catalogue)(except at individual booth construction)
- ✓ Carpet, lighting (except at individual booth construction) and electricity incl. consumption
- ✓ Hostess buffet service, cold and hot drinks, "hot small meals" as well as sandwiches, snacks, biscuit fruit etc. for your stand personnel and your visitors
- ✓ Complimentary use of the B2B area incl. catering service for your stand staff and visitors

The m² price does not includes:

- ✓ Table reservation in the lounge (950 € for co-exhibitors and 2,600 € for non-exhibitors; including table with 4 chairs, logo sign, full catering, service fee, official fair-registration, WiFi, logo promotion in channel campaigns)
- ✓ Conference cabins
- ✓ TC/Cable internet connections from fair company
- ✓ Logo artwork
- ✓ Extra entry in the fair catalogue (payment required), marketing campaigns of the exhibitor company
- ✓ Fair hostesses/Hosts for the own booth
- ✓ Daily Happy Hour, if required (extra fee)
- ✓ Stand individualizations, e.g. extra furniture (please communicate with the fair constructor – see exhibitor service catalogue). For installation of brought along exhibits, connecting cables, etc. our fair constructor charges from 55 € per hour incl. accessory charges + costs of material if any

Obligatory media fee includes:

- Entry in printed medium
- Entry in online exhibitor catalogue
- Entry in efa-App and
- Entry in the visitor information system

media partners

Building &
Automation

BUS SYSTEME

CE Markt

Channel Media
EUROPE

ChannelPartner

Consumer I.T.

DEALERS ONLY



electro



MobileChannels.eu
Smartphones, SmartDevices, SmartAccessories



POs-MAIL

Telecom Handel



22–24 SEPTEMBER 2021

GLOBAL FAIRS TT-MESSE

(hereafter named Global Fairs)

General Terms and Conditions

1. Scope of application

- 1.1. All deliveries, performances and offers of Global Fairs TT-Messe shall exclusively be subject to the below terms and conditions of lease and sale. These shall thus apply to all our present and future business relationships with customers.
- 1.2. By customers we hold „contractors“ as prescribed in § 14 BGB. Customers are natural persons or businesspartnerships with legal capacity who are exercising a professional or a commercial activity. These include the manufacturers, distributors, network operators, providers and service companies (principals) whose products we are promoting at trade shows in the brochures, catalogues etc. or on the Internet or other media, and services of any nature which we are providing for them. Furthermore, these General Terms and Conditions of Business are also applicable for all orders placed by us and all cooperation agreements.
- 1.3. All agreements entered into between Global Fairs TT Messe and the customer shall be made in writing and signed by the parties to become effective. This shall also apply to any modifications, amendments and/or the annulment of any individual term of these Terms or Conditions, including this clause.

2. Quotations and Conclusion of Contract

- 2.1. Our quotations are without obligation. All purchase orders are made in writing on the order form each supplied by us. All additional agreements absolutely require a written confirmation. This also applies to the waiver of the requirement of the specific form.
- 2.2. We reserve the right to decide on layout of the individual marketing measures. The sample designs provided by our clients, service providers, cooperation partners and customers - whether in digital or print format - for brochures, trade fair stands, etc. Representations are not binding. The same shall apply to the promotional presentation of products and services in any other media, in particular in the Internet. All individual layouts of brochures are subject to prior written agreement. We also reserve the right of optional layout for any details, which also applies for promotional presentation in all other media.
- 2.3. We do not assume any liability whatsoever for content-related or graphical representations of templates transmitted on the part of the customer.
- 2.4. The contractual relationship is concluded upon receipt of the written order of our services in accordance with our service and price list supplied by our principals.
- 2.5. Global Fairs shall be entitled to perform the tasks assigned to it themselves or to engage subcontractors or auxiliary persons to perform the work.

3. Prices

- 3.1. Our deliveries and services shall be based on the prices that are valid at the conclusion of contract. Our offered prices do not include packaging, insurance, transport or the respective value-added tax.

- 3.2. Unless explicitly agreed, any additional services or deliveries that are not mentioned in the quotation but performed at the request of the customer, will be invoiced to the customer. This also applies to additional expenditures that result from clearances made by the customer not within the agreed time, or preliminary work delivered by the customer or a third party not within schedule, or by incorrect information given by the customer after clearance or partial acceptance.
- 3.3. The quoted prices are subject to change and not binding.

4. Delivery and Performance

- 4.1. Deliveries are made directly ex print service/suppliers. We are entitled to reasonably select the way and means of dispatch and transport, unless stated otherwise in writing, according to usual business practice.
- 4.2. We only act as agents regarding the products and services promoted in the brochures and other media. As a matter of principle, we do not take over liability for the performances of third parties.
- 4.3. Our services and deliveries will be specified due to a cooperation agreement entered into with our associates/business partners for that matter..

5. Period of Delivery; Withdrawal

- 5.1. Our delivery periods and delivery dates are not binding, unless we have stated them explicitly as obligatory in any written confirmation.
- 5.2. We reserve the right to withdraw from a part of the contract or the contract as a whole if our subcontractors fail to fulfil their delivery or service in a reasonable period for reasons of force majeure, action of industrial conflict, government intervention, machine breakdown, insufficient material supply, disturbance of transporting traffic or other operational disturbances which are not our fault.
- 5.3. We are to be indemnified by him for all costs incurred by us from delayed deliveries or service by fault of the supplier/principal. This also includes print copies.

6. Organisation of Trade Shows / Events

- 6.1. The trade show / shared trade show booths organized by us are subject to the following terms and conditions: Upon receipt of the signed and returned order - also per fax or scanned and enclosed as an e-mail attachment - of a booth share including marketing services by a (co-)exhibitor, the order is considered as placed. All dimensions and sites indicated on the shared booth are to be laid out as accurately as possible. We reserve, however, the right to make changes to the booth location so as to adapt it to the requests of the organizing company and the majority of exhibitors at any given time. Unless otherwise stated, the General Terms and Conditions of Business of the main trade show organizing company are principally applicable, which are submitted to all (co-)exhibitors in due term. Unless otherwise agreed, the general terms and conditions and regulations of the main organizer of the fair, which are forwarded to the exhibitors in the registration form as far as possible via hyperlink, also apply in principle.
- 6.2. These will include, in particular, all safety regulations, the authorisation for presenting the manufactured products in the booth, the rules and regulations for promotion, and the

media partners



DEALERS ONLY





22–24 SEPTEMBER 2021

- periods of construction and dismantling and related rules and regulations.
- 6.3. We, the employees and representatives, are not liable for any accidents, losses or damages occurring to the employees of the (co-) exhibitor, of the sub-exhibitor and visitor, or for the (co-) exhibitor property. Every visitor to and participant in the (co-) exhibitors booth is considered as the (co-) exhibitor guest or licensee, not ours. The (co-) exhibitor is liable for accidents which result in damage to his property, to the visitors to his booth invited to the trade show, to a group or an individual dealer of the (co-) exhibitor, and takes over full responsibility and liability for all activities and omissions of his employees or independent visitors, whether they act in their range of competency, and takes care to indemnify us, other exhibitors and the trade show hall directly or indirectly for such omissions and measures. We are not to be made responsible for failure to fulfil the obligations by strikes, riots, political disturbances, force majeure or other reasons not within our range of power.
- 6.4. We undertake to take out an insurance policy which is usual and specific to the country, at our expense, for covering damages to third parties to an unlimited amount for the events / shared booths. But the (co-) exhibitor is always himself responsible for his exhibition material or other property, wherever it is located.
- 7. Cancellation of space**
- 7.1. Unless otherwise stated, early termination of the exhibition area agreed to by contract is possible under following conditions.
- 7.2. Complete or partial cancellation of the order given to Global Fairs can only be made in writing and by registered mail. The effective date of cancellation is the date of delivery.
- 7.3. If we receive the exhibitor's written notice of termination within a fortnight after conclusion of the contract, he is charged with a compensation fee of 10 %.
- 7.4. If we receive the notice of termination within two months before the beginning of the trade show, the compensation fee shall be 50 % of the amount of the invoice.
- 7.5. If we receive the notice for termination within 2 months and not later than 1 month before the beginning of the trade show, the full amount is due for payment.
- 7.6. Cancellation from one month before the start of the event is not permitted. This also applies to short-term contracts within these 4 weeks before the start of the event.
- 7.7. If in the cases 7.4 and 7.5 the Global Fairs succeeds in re-letting the stand area at standard conditions, it is only entitled to compensation to the co-exhibitor / exhibitor to the amount of 25% of the invoiced amount.
- 7.8. The cancellation fee will be waived if the co-exhibitor who has canceled resells the stand in its entirety to another company that meets the exhibitor criteria of Global Fairs. Already settled amounts shall be accounted for. The (co-)exhibitor acknowledges that such compensation is justified to balance both the expenditure incurred by us and the organizing company and the damages for the loss of or delay in letting the exhibition area to others.
- 7.9. If the co exhibitor does not pay the instalments each fixed by the relevant event contract, we have the right to vacate the exhibition area without further notice and hold the co - exhibitor liable.

- 8. Warranty**
- 8.1. Any rights as to defects of the buyer shall be in accordance with the German Civil Code (BGB) unless agreed otherwise.
- 8.2. In absence of any agreed specification of the services or deliveries, the existence or non-existence of a defect shall be assessed according to statutory provision. Commercial variations in quality and colour and those which are only slight or technically not avoidable are not considered as deficiencies and may not be complained of by our partners/principals.
- 8.3. All delivered services and objects from Global Fairs shall be subjected to a review by the customer on receipt or latest before use. Any complaints of defects must be made in writing. A reasonable time limit of two weeks from delivery service shall be agreed upon. Any later complaint of a defect or defects shall be considered only if the customer shows that it could not reasonably be expected to or was not able to make an earlier investigation and complaint.
- 8.4. The customer has to give us the opportunity and a fair amount of time to convince ourselves of the defect and carry out the required subsequent fulfillment and improvement. In the case of only a minor nonconformity, uncluding but not limited to only minor defects, the customer shall not be entitled to cancel the contract. Our right to refuse subsequent fulfillment and improvement according to statutory provision shall remain unaffected by this.
- 8.5. We do not assume any responsibility for any details in the brochures and other promotion material, in particular not for printed prices, nor for the representation in pictures and descriptions.
- 8.6. We do not guarantee the availability of the goods and services promoted in the brochures and other advertising media.
- 8.7. We do not grant any liability for any deficiencies resulting from failure of our partners/manufacturers by not keeping the due delivery dates in case of promotion projects.
- 8.8. Suppliers and supply companies assume warranty for the delivery and performed services according to legal provisions.
- 9. Liability**
- 9.1. We only grant liability for cases of malicious intent and gross negligence and also other reasons which cannot be excluded according to legislation. Any further liability is excluded.
- 9.2. Global Fair is not liable for verifying any infringement of protective rights of third parties by the transfer of documents or information in connection with the service provision. The customer agrees to exempt Global Fairs from any claims of compensation of third parties and to assume liability for all damages that result from the infringement of protective rights. The customer also agrees to pay a reasonable advance indemnity when necessary.
- 9.3. Any claims against us, on whatever legal grounds, will expire by the end of 12 months after transfer of risk to our partner, unless otherwise demanded by legal regulations.
- 9.4. The aforementioned regularions and restrictions of liability also apply to auxiliary persons and vicarious agents of Global Fairs.
- 10. Conditions of payment**
- 10.1. If applicable, agreed monthly contributions and payments as well as ordered advertising products and services of our

media partners



DEALERS ONLY



clients and customers can be withdrawn by prior arrangement by means of a direct debit procedure.

Our deliveries and services are, if not expressly agreed to otherwise in writing, due for payment upon receipt of invoice and not later than 10 days from date of invoice, without deduction.

- 10.2. We are entitled to set off the payments from our partners or from other customers/principals of ours against other unpaid claims due for payment, even if the payment orders from our partner/other customers of ours/principal states differently.
- 10.3. The set-off against a counterclaim and the right of retention which is rejected by us or not legally confirmed is not permitted.
- 10.4. If we learn of any circumstances which we esteem to give reasonable doubt as to the credibility of our partner or our other customers/principals, we have the right to either withdraw from the contract or to deliver only after prior payment for the delivery.
- 10.5. In case of delayed payment by our partners or our other customers and principals, we are entitled to invoice default interest to the amount of 8%. This does not affect our right to claim any higher default damages. Our partners or our other customers/principals have the right to present evidence to us of a lower amount of damage caused by the delay.
- 10.6. We are not obliged to complete any deliveries and services under current contracts until all due amounts of invoices including all interest and possible expenditure have been settled.
- 10.7. The costs for default of payment, of a reminder of payment and legal proceedings including all action to be taken (such as banking fees collection of information, commissioning of a debt collecting agency) are in the responsibility of our partner or of our other customers, suppliers and principals.
- 11. Reservation of Proprietary Rights**
- 11.1. All products delivered will remain our property until all claims under the business relationship with our principal are settled, including interests.
- 11.2. The principal is entitled to transfer the goods under reserved property in normal business. The principal assigns to us herewith all accounts receivable resulting from the resale including possible securities to the amount of the due purchase price. Should the goods under reserved ownership be sold along with other goods not belonging to us, the assignment of claims from the resale only to the amount of the value of the goods under reserved ownership.
- 11.3. The principal is entitled to collect claims from the resale until this authorisation is withdrawn by us, which is permissible at any time. Upon our request, he is obliged to notify his customers of the assignment to us and make available to us all information and documents required for collection of debts. Apart from that, we are ourselves entitled to disclose the assignment towards his customers at the principal's expense. Claiming the reservation of property is only deemed as a withdrawal from the contract if we express this in writing.
- 11.4. No mortgaging or pledging of goods under reserved property to third parties is allowed. In case of seizure, the principal is to expressly indicate the reservation of property and inform us immediately.

- 11.5. In case of default of payment, suspension of payment, (filing for insolvency protection or bankruptcy petition by the principal or one of his creditors), we are entitled notwithstanding all further rights to take the goods under reserved property back and use them otherwise. The proceeds — following deduction of all expenditure relating to the use of the goods, which we are allowed to invoice without any proof up to 20 % of the proceeds of the use, unless the principal makes evident a lower amount of damage to us, is to be credited to the principal to his total sum of debts: a possible surplus is to be paid to the principal.
- 11.6. If the value of the securities to which we are entitled exceeds by more than 20 % the total debt claim against the principal, we shall be obliged in this respect to release at our choice some of our securities upon request by the principal.

12. Note on data processing and credentials

- 12.1. Data that has been obtained in connection with the business relationship will be processed as defined by the German data protection act. The customer approves that data that is granted by himself or by a third party maybe collected and processed in compliance with the relevant legal provisions on data protection. This includes the existence of necessary consents by persons concerned and it follows that the use of these data by Global Fairs will not infringe upon applicable laws or regulations in connection with the placed order.
- 12.2. Global Fairs is entitled to use any products as well as name and logo of the customer for purposes of data processing, credentials or self-advertising free of charge after termination of the contract.

13. Concluding Provisions

- 13.1. The place of fulfilment and jurisdiction for all matters of dispute arising from these terms and conditions will be Osnabrück, Germany. We reserve, however, the right to bring the matter before the court which is competent for the district of the offices of our contractual partner.
- 13.2. All contractual relations are governed by German law. In special cases the uniform UN purchasing law (United Nations Convention on Contracts for the International Sale of Goods) shall apply.
- 13.3. Should a stipulation in these General Terms and Conditions of Business be invalid or include a gap, this shall have no effect on the legal validity of the remaining stipulations. As a replacement of the invalid stipulation, a valid stipulation is deemed to have been agreed which comes as close as possible to the contractual purpose striven for by the contractual parties if they had been aware of this matter.

Effective November 2017